

CD120-MEC (mechanical device) – MEASUREMENT RANGE UP TO 3500 MM

Specifications:

Measurement range	0 up to 3500 mm
Circumference drum	300 mm/turn
Sensing device	Adaptable with all our incremental or absolute encoders
Material	Body and cover - aluminium (RohS) Measuring cable – Stainless steel 316L
Cable diameter	0,60 mm
Standard linearity	+/- 0,05% f.s. +/- 0,01% f.s. (optional)
Max. Velocity	10 m/s
Max. Acceleration	7 m/s ² (before cable deformation)
Weight	≈ 2000 g
Operating temperature	-20° to +80°C
Storage temperature	-30° to +80°C

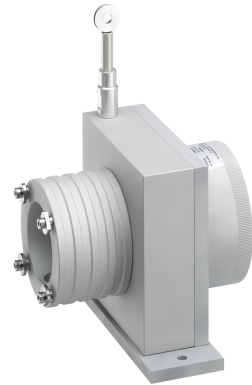

Cable forces:

Measurement range in mm	Min. pull-out force	Max. pull-out force
3500	≈ 13,00 N	≈ 18,00 N

Ordering reference:

CD120 – MEC – 3500 – 300 – L05 – OP – xx – xx

Model	CD120
Measurement range	3500 = 0 to 3500 mm <i>Or other ranges between 0 and 3500mm</i>
Drum circumference	300 = 300 mm/turn
Linearity	L05 = +/- 0.05% f.s. L01 = +/- 0.01% f.s. (option)
Option OP	06 = Adapter flange for Ø58 encoder with Ø6 axis (06A for the provision of a Ø6 coupling device without flange) 10 = Adapter flange for Ø58 encoder with Ø10 axis 12 = Adapter flange for Ø90 encoder with Ø12 axis (12A for the provision of a Ø6 coupling device without flange) AC = Complete anodizing BR = Cleaning brush for the measuring cable BT = Low temperature (down to -30°C / dry cold) CP = Fixing of the measuring cable with a clevis EN = Measuring cable coated with polyamide (<i>Measurement range limited to 2500 mm</i>) M4 = Fixing of the measuring cable with a M4 threaded rod TEV = Water evacuation holes

If no option is specified for the adapter flange, the draw-wire sensor will be supplied as standard with a Ø10 coupling brace without a flange. For the adaptation of an encoder or other sensor device which does not belong to our range, please contact us.



Dimensional drawing:

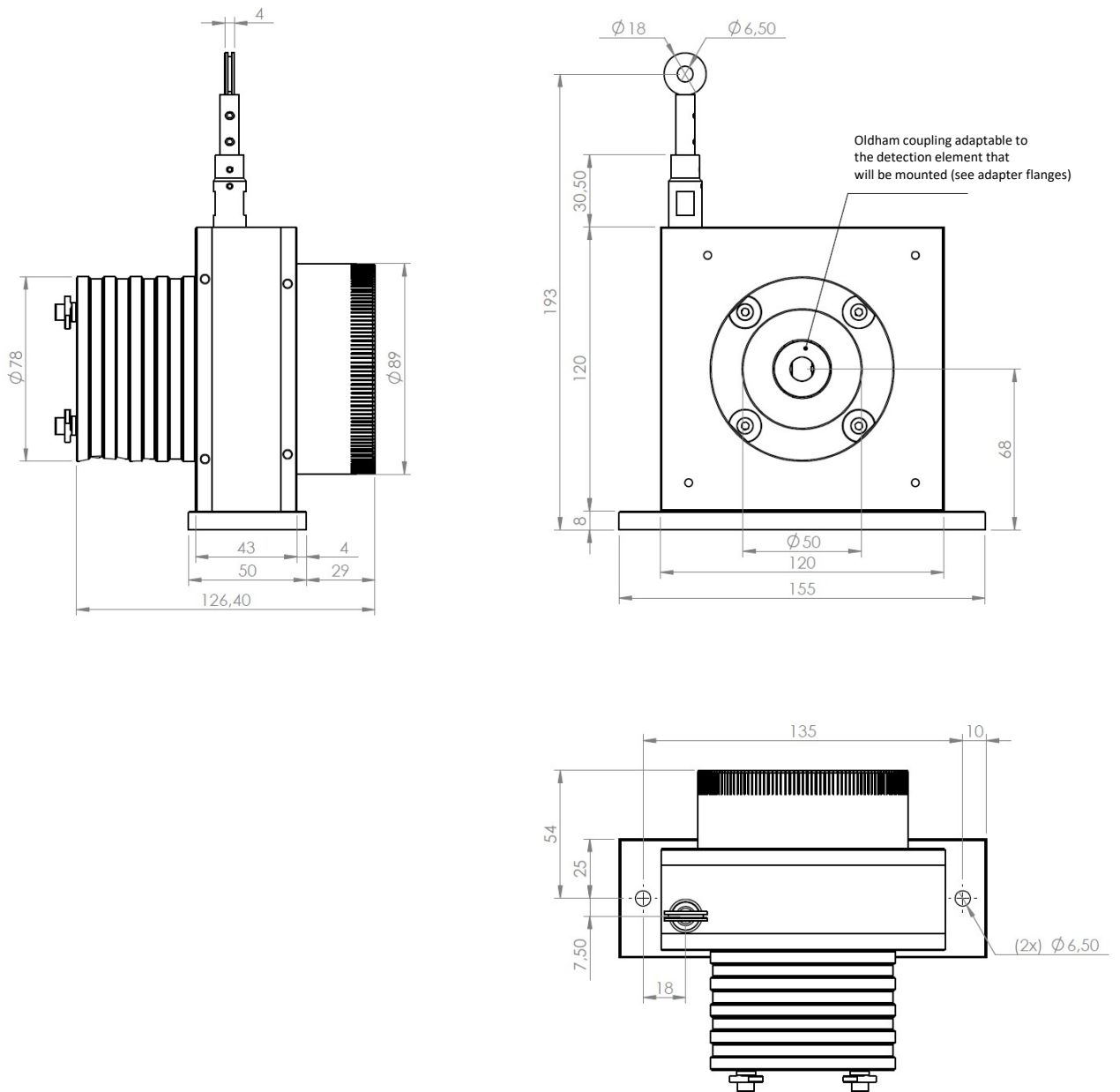

Changing the base plate position

1. Unscrew the 4 M4x10 screws holding the base plate
2. Position the base plate on the desired face
3. Fix the base plate using the 4 screws M4x10

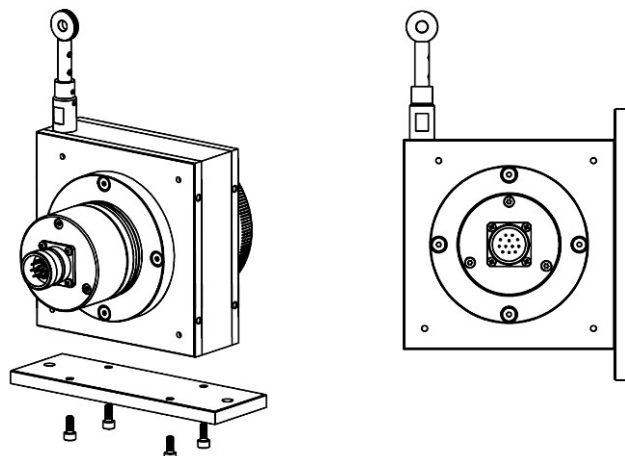

Adapter flanges

Adaptation for an encoder of diameter 58mm, and shaft diameter 6mm

OP-06: Adaptation flange + Ø6 Oldham coupling

OP-06A: Ø6 Oldham coupling without adaptation flange

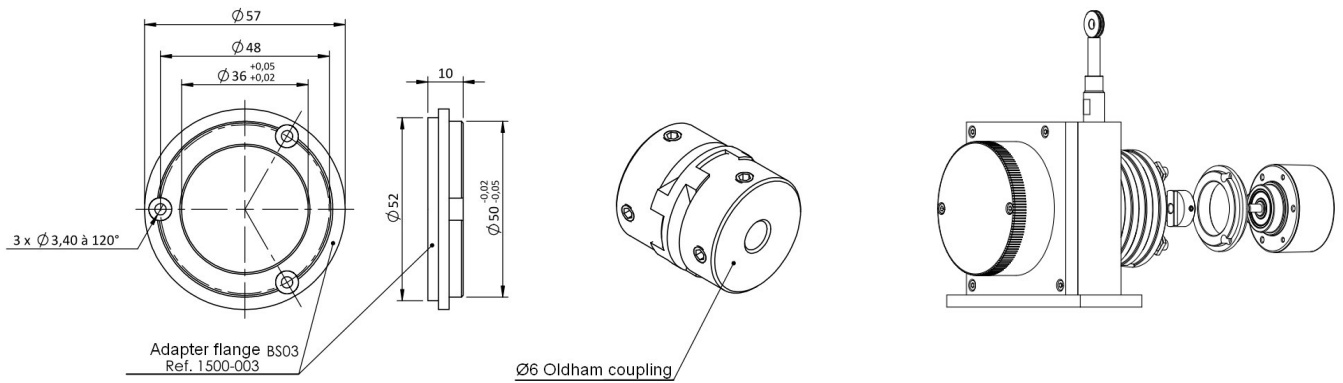

Adaptation for an encoder of diameter 58mm, and shaft diameter 10mm

OP-10: Adaptation flange + Ø10 Oldham coupling

Without specification, a MEC series draw-wire sensor will always be delivered with an Oldham coupling Ø10 without adaptation flange.

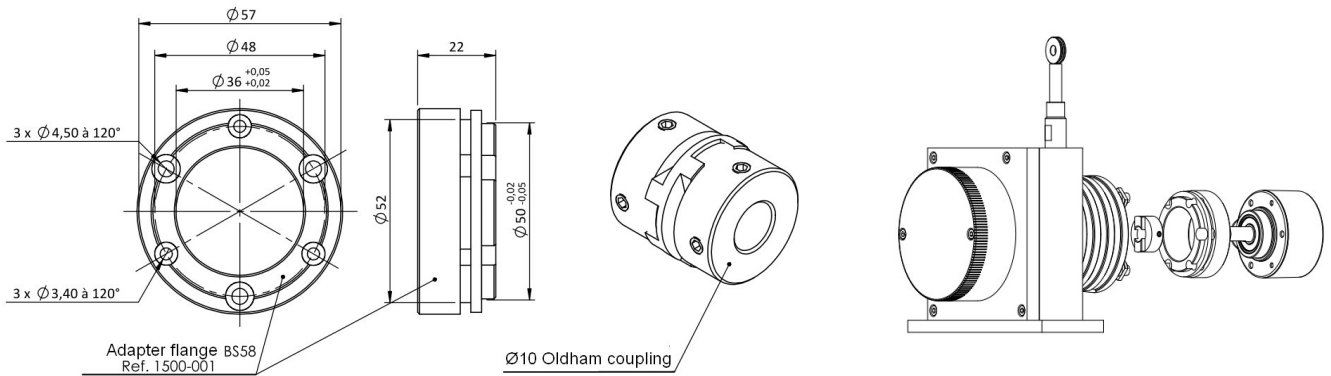

Adaptation for an encoder of diameter 90mm, and shaft diameter 12mm

OP-12: Adaptation flange + Ø12 Oldham coupling

OP-12A: Ø12 Oldham coupling without adaptation flange

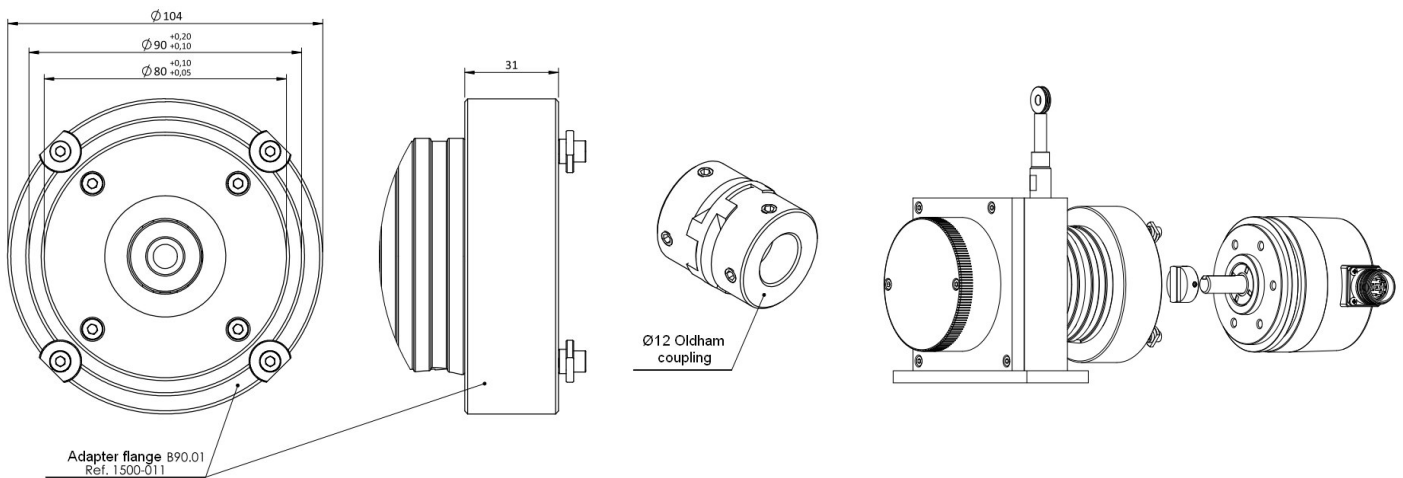

Options:

Cable attachment with a lug :

Standard

The attachment lug is fixed with a M6 screw or a clevis.

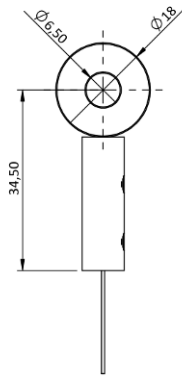

Cable attachment fitted with a M4 threaded rod:

OP-M4

The rod attachment uses a threaded rod with 2 nuts (provided). The required thickness of the plate does not exceed 5 mm.

Caution

Never screw the threaded rod into a fixed nut, a twist of the measurement cable would damage it.

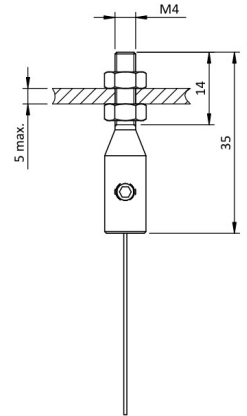

Cable attachment with a clevis :

OP-CP

The attachment of the clevis is done using a pin (provided).

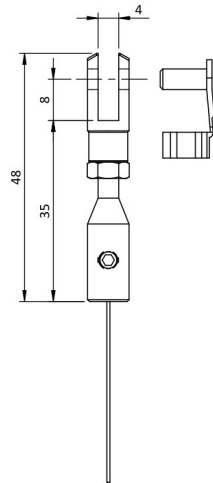

Cable cleaning brush:

OP-BR

The cleaning brush wipes the cable in dusty or humid environments.

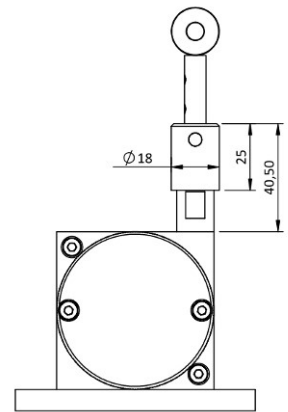

Water evacuation holes:

OP-TEV

The holes allow the natural flow of fluids out of the sensor in order to avoid their accumulation in the system.

